

NORTHERN TERRITORY DEEMED TO COMPLY MANUAL - National Construction Code (NCC) Volume 2

This product has been determined to satisfy NCC Performance Requirement H1P1 for structural resistance of materials and forms of construction in high wind areas

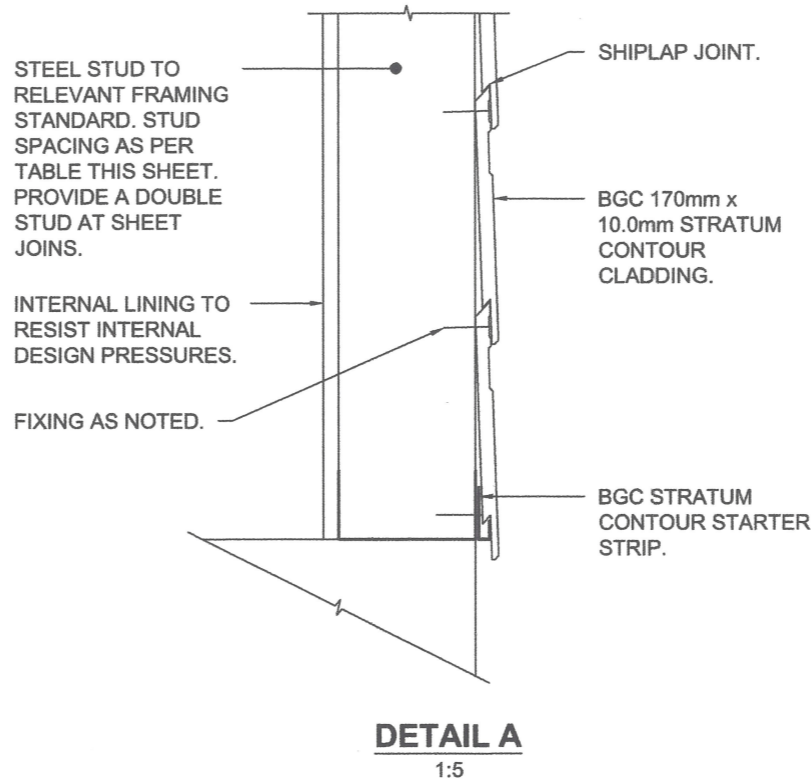
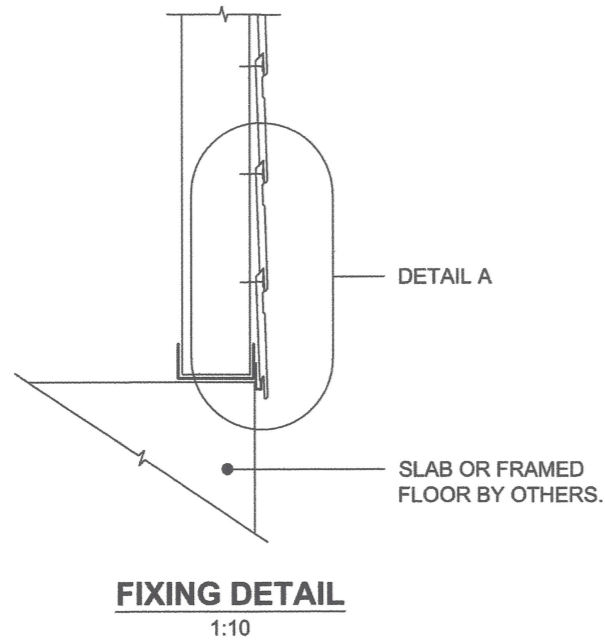

Product Name  
**10.0mm 'STRATUM CONTOUR'**  
Fibre Cement Cladding

Product Description  
**EXTERNAL WALL CLADDING TO STEEL FRAMING**

Manufacturer's Details  
**BGC Fibre Cement (Australia) Pty Ltd**

38-40 Magnet Rd, Canning Vale, WA 6155 Australia  
PO Box 7223, Cloisters Square, WA 6850 Australia

**Design Criteria**

1. WIND CLASSES N4-N6 AND C1 TO C4 TO AS4055-2021 WIND LOADS FOR HOUSING.
2. WIND CLASSES ARE AS OUTLINED IN AS4055-2021 WIND LOADS FOR HOUSING
3. THE CAPACITIES AND FIXING REQUIREMENTS SHOWN ON THIS CERTIFICATION ARE SUITABLE FOR FIXING TO STEEL STUDS.
4. A MATERIAL CAPACITY REDUCTION FACTOR OF 0.8 HAS BEEN USED FOR ALL PROOF TESTING BY BRANZ AND CYCLONE STRUCTURAL TESTING STATION.
5. FIBRE CEMENT SHEETS HAVE BEEN MANUFACTURED IN ACCORDANCE WITH AS/NZS 2908.2:2000 CELLULOSE CEMENT PRODUCTS PART 2: FLAT SHEETS OR ISO 8336:2018 FIBRE CEMENT FLAT SHEETS - PRODUCT SPECIFICATION AND TEST METHODS.
6. THE FOLLOWING STANDARDS APPLY TO THIS DESIGN:  
AS/NZS1170.0:2002 (Incl. Amdt 1,2,3,4,5), AS/NZS1170.1:2002 (Incl. Amdt 1,2 & R2016), AS/NZS1170.2:2021 (Incl. Amdt 1), AS4040.0:1992 (R2016), AS4040.1:1992 (R2016), AS4040.3:2018, AS4055:2021, AS4100:2020 (Incl. Amdt 1), AS/NZS4600:2018.

**Limitations**

1. BGC CLADDING TO BE PAINTED TO BGC SPECIFICATIONS.
2. DOMESTIC HOUSING WITH MAXIMUM BUILDING DIMENSIONS AND LAYOUT AS PER AS4055:2021 - WIND LOADS FOR HOUSING.
3. WALL PANELS TO BE 2700mm HIGH MAX.
4. THIS TABLE IS FOR FIXING TO A STEEL FRAME ONLY, WITH FIXING AS DETAILED ON THIS SPECIFICATION. FIXINGS ARE NOT TO BE OVER-DRIVEN INTO FIBRE CEMENT SHEETING, AND ANY OVER-DRIVEN FIXINGS ARE TO BE REPLACED.
5. STUD CAPACITY MAY BE LIMITING, AND IS TO BE CHECKED SEPARATELY BY A QUALIFIED ENGINEER. THE VALUES PRESENTED IN THIS DRAWINGS ARE THE MAXIMUM STUD SPACINGS REQUIRED TO SUPPORT THIS CLADDING.
6. 10.0mm STRATUM CONTOUR IS AN EXTERNAL WALL CLADDING SUBJECT TO ONLY EXTERNAL PRESSURE AND SUCTION LOADINGS. INTERNAL LININGS COMPETENT TO RESIST INTERNAL DESIGN PRESSURES MUST BE INSTALLED. THE RAKING STRENGTH HAS NOT BEEN TESTED AND THEREFORE SHOULD NOT BE ALLOWED FOR IN THE DESIGN OF A STRUCTURE.
7. TESTING WAS CONDUCTED FOR NEGATIVE (SUCTION) PRESSURES ONLY. COMPARISON HAS ONLY BEEN MADE BETWEEN THESE VALUES AND THE NEGATIVE ULS VALUES WHICH ARE DEEMED TO GOVERN.

**Accepted for inclusion in Deemed to Comply Manual**

DTCM drawing number: M/374/01

Chairperson Signature:

Chairperson Name: Paul Nowland

Date of Approval: 1/09/2023 Expiry Date: 1/09/2028

STRATUM CONTOUR WEATHERBOARD WALL CLADDING TABLE				
WIND CLASS	ULTIMATE LIMIT STATE - EXTERNAL PRESSURE (kPa)		MAXIMUM STUD SPACING (mm)	
	WITHIN 1200mm OF CORNERS	ELSEWHERE ON THE BUILDING	WITHIN 1200mm OF CORNERS	ELSEWHERE ON THE BUILDING
N4	-2.90	-1.45, +1.56	450	450
N5	-4.27	-2.14, +2.30	450	450
N6	-5.77	-2.88, +3.11	300	450
C1	-1.95	-0.98, +1.05	450	450
C2	-2.90	-1.45, +1.56	450	450
C3	-4.27	-2.14, +2.30	450	450
C4	-5.77	-2.88, +3.11	300	450

**CONSTRUCTION NOTES:**

1. BGC 10.0mm STRATUM CONTOUR CLADDING IS TO BE FIXED TO STEEL WALL FRAMING AS PER THE ABOVE TABLE AND THE BELOW NOTES:
  - STEEL WALL FRAMES TO BE CONSTRUCTED IN ACCORDANCE WITH THE NATIONAL ASSOCIATION OF STEEL FRAMED HOUSING STANDARD - DESIGN OF RESIDENTIAL AND LOW-RISE HOUSING, NASH:2009 & NASH PART 1:2005 (Incl. Amdt A, B, C).
  - ALL STEEL WALL FRAME MEMBERS TO BE IN ACCORDANCE WITH AS4600:2018 WITH MINIMUM THICKNESS TO BE 0.75mm. (MINIMUM GRADE G550).
  - FIXINGS:
    - FOR FIXING INTO STEEL 0.75mm TO 1.0mm USE No.10-16x30 COUNTERSUNK TEK SCREWS.
    - FOR FIXING INTO STEEL GREATER THAN 1.0mm USE No.8-18x35 COUNTERSUNK TEK SCREWS.
  - WHEN INSTALLING CLADDING OVER INSULATION, INCREASE THE SCREW LENGTH TO ENSURE A MINIMUM OF TWO THREADS PROTRUDE THROUGH THE FAR SIDE OF THE SUPPORT.
  - ALL FIXINGS TO BE CLASS 4 FINISH.
  - ALL FIXINGS ARE TO BE A MINIMUM OF 20mm FROM CORNERS AND EDGES OF SHEETS (SEE DETAIL A).
  - PROVIDE A DOUBLE STUD AT PLANK JOINS. PLANK JOINS AND ENDS OF PLANKS TO BE FIXED ON-STUD FOR ALL WIND CASES. STUD SPACING AS PER TABLE THIS SHEET.

Notes covering basis of DTC (Relevant test reports etc)

- TABLES ARE BASED ON A TEST PROGRAM TO AS4040.3:1992 CLAUSE 6, CARRIED OUT BY JAMES COOK UNIVERSITY TESTING STATION IN APRIL 2018 (TS1105a).
- IT IS CONFIRMED THAT THE REQUIREMENTS OF AS4040.3:2018 C16 ARE CONSISTENT WITH THOSE IN THE 1992 EDITION OF THE CODE.
- THE NEGATIVE ULS PRESSURES ARE DEEMED TO GOVERN, DUE TO THE ASSOCIATED CRITICAL FAILURE MECHANISM.

**Checking Engineer**

Name: ALAN DOWLING  
Registration Number: NER 3251796  
Date: 14/8/23  
Signature:

Must be an Australian registered structural engineer

**Certifying Engineer**

Name: ADAM JAMES  
NT Registration Number: 26968ES  
Date: 15/08/2023  
Signature:

Must be a registered structural engineer in the Northern Territory