

IN ACCORDANCE WITH NCC VOLUME 2 (SECTION P3.10.1), THIS PRODUCT SATISFIES PERFORMANCE REQUIREMENT P2.1.1 FOR CONSTRUCTION IN A HIGH WIND AREA

**SPECIFICATION**

This data sheet covers the use of 6mm HardieFlex™ and 6mm Panelclad® sheet cladding in residential façade applications over a light-gauge steel frame or a timber wall frame and must be read in conjunction with current James Hardie product literature, namely the "External Cladding Technical Specification". The sheets must be coated in accordance with the product literature.

**FRAMING & SHEET INSTALLATION**

Install sheets vertically to steel or timber stud-frames as shown in Figure 1 and in accordance with the stud and fastener spacing given in Table 1 and Table 2 depending on the wind load classification or design pressure.

Framing width at sheet joints must be a minimum of 42mm for timber and 38mm for steel. Where the studs at sheet joints are less than this, provide double 35mm wide studs at sheet joints. Ensure that double studs are fastened together and flush at the outside face.

All intermediate support studs must be a minimum of 64 x 35mm deep for metal framing and 70 x 35mm for timber.

All sheet edges and joints must be supported by framing.

**Framing – Steel**

The steel frame must be in accordance with AS 3623: 1993 "Domestic Metal Framing". Studs shall be rolled steel sections not exceeding 2mm in thickness.

**Framing – Timber:**

Use of timber framing must be in accordance with AS 1684: 2010 "Residential timber-framed construction" and framing manufacturer's specifications. Use seasoned timber or else unseasoned hardwood minimum F14 grade. LVL timber may be used.

Spacing of the M12 cyclone rods to be determined from AS 1684.3: 2010, but never more than 2.4m apart if bracing capacity is claimed.

**Jointing:**

HardieFlex sheets are normally jointed with a PVC straight joint mould and finished at corners with surface mounted PVC corner moulds.

Both types of Panelclad sheets are joined with a PVC mould, both can be finished at corners with surface mounted PVC corner moulds.

Sheet joints must coincide with the centre line of the framing member (see Figure 2).

**FIXING / FASTENERS**

All fixings and fastener to be minimum Class 3 finish. Use the following fasteners or approved equivalent fasteners:

**Fasteners - Steel Framing:**

Use 30mm Buildex FibreZIP® or 32mm HardieDrive® screws.

**Fasteners - Timber Framing:**

Use a 2.8 x 30mm galvanised fibre cement nail.

**TABLE 1: Max Stud & Fastener Spacing for Wind Pressure**

AS 4055 Wind Load Class	General Areas Of Building			Within 1200mm of Building Edges		
	ULS Pressure (kPa)	Stud (mm)	Fastener (mm)	ULS Pressure (kPa)	Stud (mm)	Fastener (mm)
C1	-0.98 +1.05	600 or 450	200	-1.95	450	200
C2	-1.45 +1.56	450	200	-2.90	450	150
C3	-2.14 +2.30	450	200	-4.27	300	150
C4	-2.88 +3.11	450	150	-5.77	300	100

**TABLE 2: Test-Proven ULS Design Pressure Capacity**

Stud Spacing (mm)	Fastener Spacing (mm)	ULS Pressure (kPa)
600	200	1.3
450	200	2.3
450	150	3.2
300	200	3.6
300	150	4.3
300	100	6.0

**STRUCTURAL BRACING**

Table 3 provides the ULS design bracing capacity of 6mm James Hardie FC cladding when fixed vertically in accordance with Tables 1 or 2 with fastener spacing additionally as per James Hardie's "Structural Bracing Application Guide". Capacities are for wall heights of both 2400mm and 2700mm.

**TABLE 3: ULS Design Bracing Capacity**

Framing Details	Max Stud Spacing (mm)	Bracing Capacity (kN/m)	
		Single-Sided	Double-Sided
Timber framing with M12 cyclone rods	600	5.3	7.3
Welded steel framing 1.2mm gauge	450	5.8	6.0
Welded steel framing 1.6mm gauge	450	6.0	7.8
	300	7.5	11.0

Note: Double-sided means that there is an internal lining of James Hardie fibre-cement sheet of thickness at least 6mm with fasteners spaced at 200mm maximum throughout the sheets. Refer also the James Hardie DTC sheet for structural bracing.

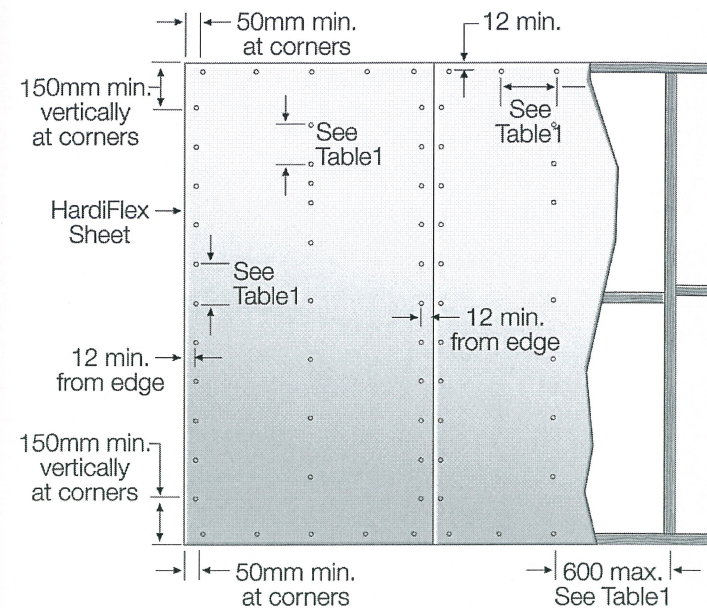

**Figure 1: Sheet Fastening Spacing**  
(fixing to noggings not required)

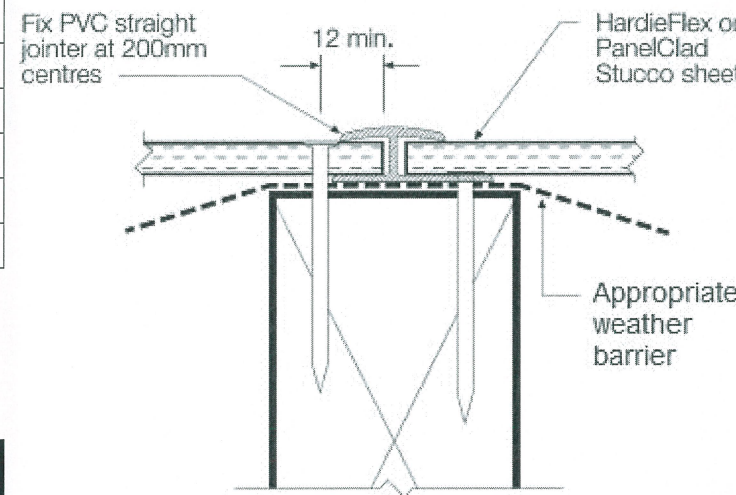

**Figure 2: Sheet Joint on Timber Framing**  
(steel framing similar)  
(thermal break may be required)

**DETAILS & OTHER MATTERS**

More extensive construction details and jointing details are provided in current James Hardie literature for HardieFlex and PanelClad cladding. Refer also to the Warranty in that literature.

For further details on matters such as a thermal break, an appropriate weather barrier (eg vapour permeable sarking), flashing, system accessories and finishing, refer to current James Hardie technical literature for HardieFlex and PanelClad cladding, the BCA or relevant Australian Standards.

Product Name:  
**HARDIEFLEX™ & PANELCLAD® SHEET**

Product Description:  
**6mm External Cladding for Walls**

Manufacturer's Name:  
**James Hardie Australia Pty Ltd**  
10 Colquhoun Street, Rosehill NSW 2142



**Design Criteria:**

[1] **General**  
All design and construction must comply with the appropriate requirements of the current Building Code of Australia (BCA) and other applicable regulations and standards.

[2] **Wind Loading**  
The cladding sheet must be fastened to the frame in accordance with Table 1 for the different wind classifications, which are taken from AS 4055: 2006 "Wind Loads for Housing". The effective design wind speeds are given in Table 2.1 of AS 4055.

For design to AS/NZS 1170: 2011 Part 2 "Wind Actions", the test proven ULS design capacity of the system is given in Table 2, noting that an ULS material capacity reduction factor ('phi') is implicitly included and no further factoring of the design capacity is needed:

**Limitations:**

[1] HardieFlex and PanelClad sheets are external wall cladding for residential use only. This cladding has been designed for external pressure and suction loadings only. The designer must ensure that the framing is capable of resisting simultaneously the internal and external design pressures (ie an internal lining is required).

[2] To use Table 1, the design must comply with the geometric limits given at Clause 1.2 of AS 4055: 2006 (eg max eaves height = 6m and max building width = 16m), except as varied by the design engineer.

[3] Fastening: All fasteners specified must be driven flush. Do not fix fasteners closer than 12mm from panel edges, or closer than 50mm from sheet corners.

**Accepted for Inclusion**

DTCM ref:  
M/269/01

Chairman's Signature:

Chairman's Name:  
DAVID BENEKE

Date of Approval: 30/07/2015  
Expiry Date: 30/07/2020

**Notes covering basis of DTC (relevant test reports etc):**

The nominated structural capacity of the system is based on the following documentation:

- [1] James Hardie Advice Note dated 31 July 2010 "Addendum to the June 1995 Submission on the Derivation of Design Tables for External Cladding Systems in the Northern Territory".
- [2] James Hardie Submission dated 30 June 1995 "Derivation of Proposed Design Tables for Eaves & Soffit Linings & External Cladding Systems for Use in the Darwin Deemed-to-Comply Manual", which includes uniform load testing reports by Karl Danenbergsons dated 13 April 1995 and Clayton Frick dated 30 June 1995.
- [3] James Hardie letters dated 7 August 1996 to the NT Building Advisory Services Branch and Colless & O'Neill Pty Ltd regarding the outcome of testing cyclic versus static loading.
- [4] Cyclone Structural Testing Station Report No. TS 471 dated 23 July 1996 "Static and Cyclic Uniform Loading of HardieFlex Cladding".

**\*Design Engineers Certification**

Name: KEVIN LEEDOW  
Cardno (NSW) Pty Ltd  
Rego Number: IEAUST 406617  
Date: 16 June 2015  
Signature:   
\*registered as a structural engineer in Australia

**\*\*Certifying Engineers Certification**

Name: DAVID BENEKE  
NT Rego Number: 58478 ES  
Date: 17 June 2015  
Signature:   
\*\*registered as a structural engineer in Northern Territory