

ELEVATION ON WIND LOCK
4.0mm GALVANISED FOLDED MILD STEEL

DOOR DRUM SUPPORT BRACKET TO MANUFACTURE DETAILS.



TYPICAL ROLLER DOOR SLAT

SCALE 1:2

NOTES:-

1. APPROXIMATE COVER WIDTH TO SLAT 100mm.
2. SLAT SHALL BE COLD ROLLED FROM 0.8mm BMT STEEL STRIP GRADE 300 (EX G2-275 GALVABOND STEEL STRIP)

DOOR MATERIAL TABLE

DOOR WIDTH (mm)	WIND LOCK SPACING	END GAP (mm)	ULTIMATE DESIGN RESISTANCE (kPa)	ULTIMATE REACTIONS (kN/m)
4000	EVERY 4th SLAT	40	3.0	X=13.8 Y=6.2
6000	EVERY 2nd SLAT	40	3.0	X=27.2 Y=9.2
8000	EVERY 2nd SLAT	40	3.0	X=45.9 Y=12.2

X = HORIZONTAL REACTION IN PLANE OF DOOR
Y = HORIZONTAL REACTION PERPENDICULAR TO PLANE OF DOOR

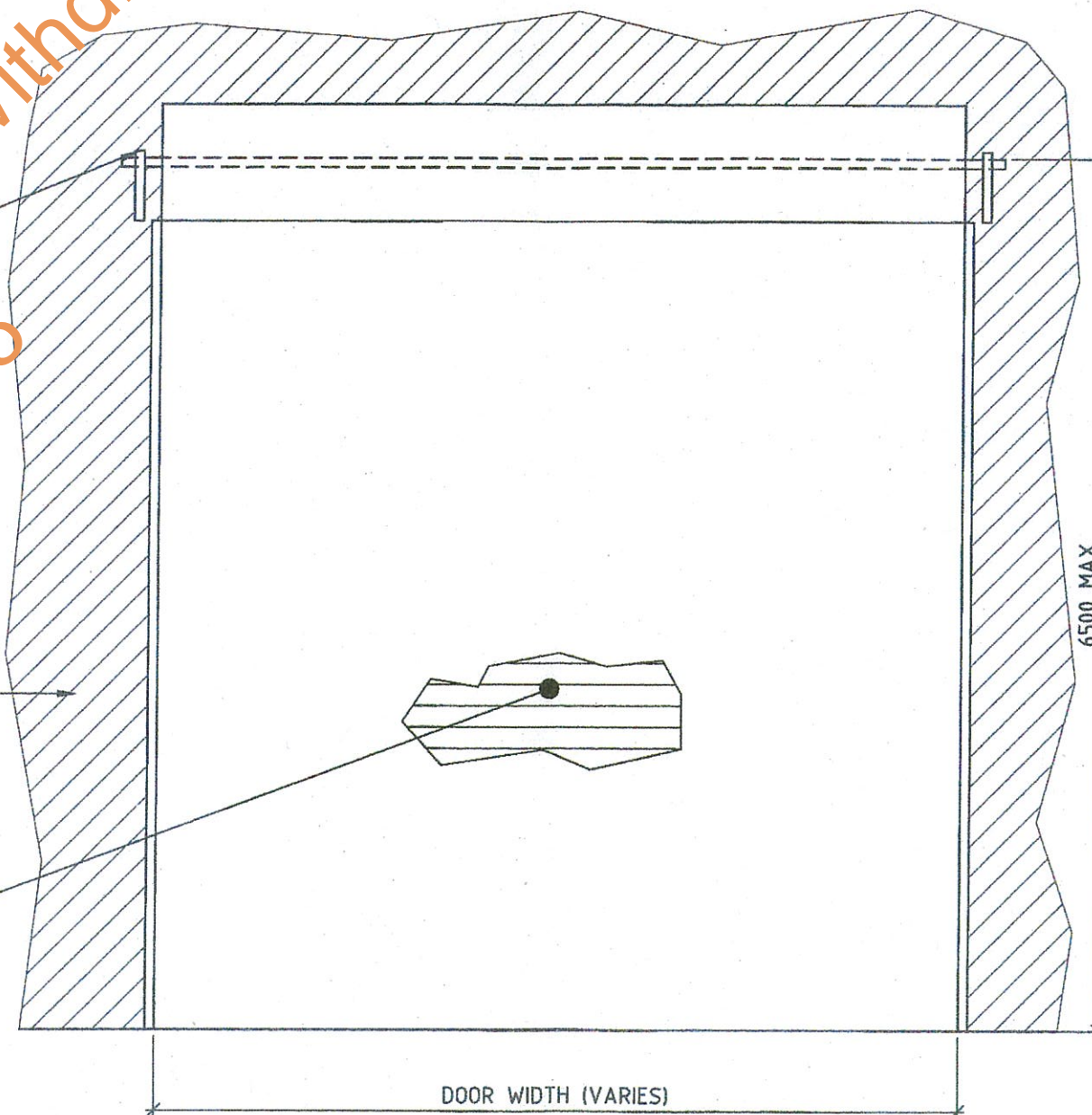

TYPICAL ROLLER DOOR ELEVATION (INSIDE VIEW)

SCALE 1:50

Product name
ROLLER SHUTTER DOORS 0.8mm BMT WITH WIND LOCKS

Product Description
ROLLER SHUTTER DOORS 0.8mm BMT WITH WIND LOCKS

Manufacturer's Name
ARCO (QLD) PTY LTD
PH (07) 38078041

Design Criteria

1. ULTIMATE DOOR DESIGN RESISTANCE 3.0 kPa.
2. ROLLER DOOR SUPPORT STRUCTURE TO BE DESIGNED BY MAIN BUILDING DESIGN ENGINEER FOR LOADING INDICATED. SEPARATE SECTION 40 CERTIFICATE IS REQUIRED FOR MAIN BUILDING DESIGN.
3. SUITABILITY OF DOOR FOR ACTUAL SITE CONDITIONS TO BE MADE BY MAIN BUILDING DESIGN ENGINEER. (LIMITED TO 3.0kPa ULTIMATE DESIGN PRESSURE).

Limitations

1. 6500 MAX DOOR HEIGHT
2. 8000 MAX DOOR WIDTH
3. END GAPS MUST BE SET AS INDICATED IN TABLE.
4. MAX 10,000 BUILDING EAVES HEIGHT
5. LOCAL PRESSURE EFFECTS ARE DEPENDANT ON THE FINAL BUILDING CONFIGURATION. WHERE DOORS ARE LOCATED WITHIN 6.0m OF AN EXTERNAL CORNER, THE DOOR SHALL BE ASSESSED FOR LOCAL PRESSURE EFFECTS IN LINE WITH ITEM 1 OF THE DESIGN CRITERIA STATED ABOVE, AND THE DESIGN REAPPRAISED AS REQUIRED. THE ASSUMED MAXIMUM PLAN DIMENSION (B or D) FOR THE CALCULATION OF LOCAL PRESSURE DIMENSION 'a' SPECIFIED IN CLAUSE 5.4.4 OF AS1170.2 IS 36.0m.

Accepted for Inclusion

DTCM ref: M/176/01 SHEET 1 OF 2

Chairman's Signature:

Chairman's Name: STEVEN J EHRLICH

Date of Approval: 29/11/2012 Expiry Date: 29/11/2015

Notes covering basis of DTC (Relevant test report etc)
REFER TO NJA CONSULTING REPORT - REFERENCE No. 11106-028-01

****Certifying Engineer's Certification**

Name: RONALD A. BELL
Registration Number: 60596 ES
Date: OCTOBER 2011
Signature:

**registered as a structural engineer in Northern Territory

***Design Engineer's Certification**

Name: DARREN McDONALD
Registration Number: 24619 ES RPEQ 5453
Date: OCTOBER 2011
Signature:

*registered as a structural engineer in Australia

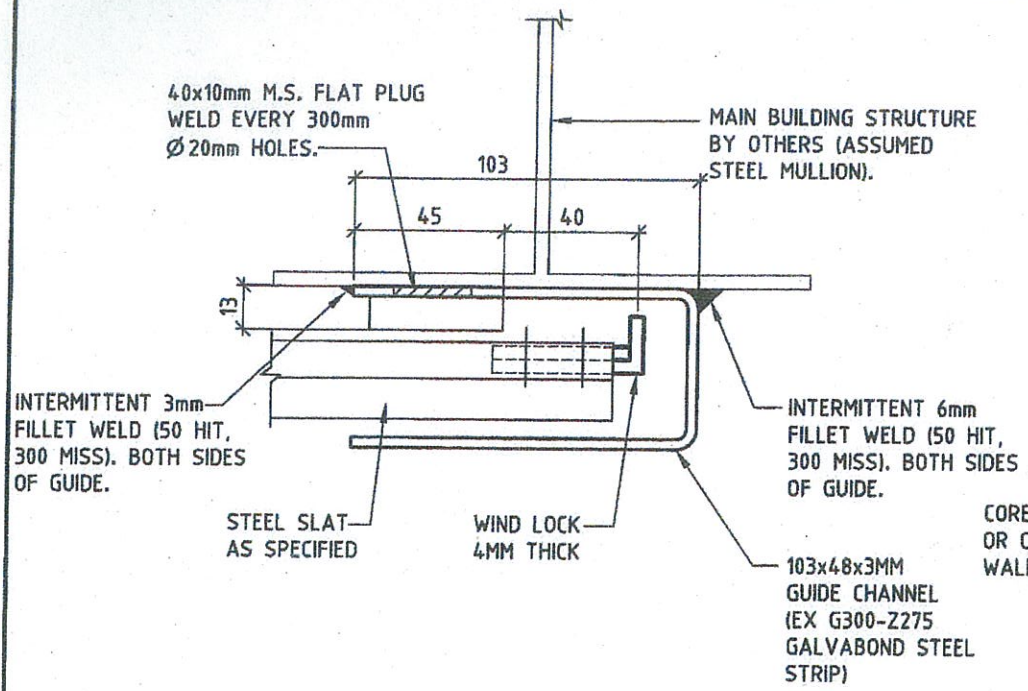

TYPICAL ROLLER DOOR GUIDE DETAIL

NTS

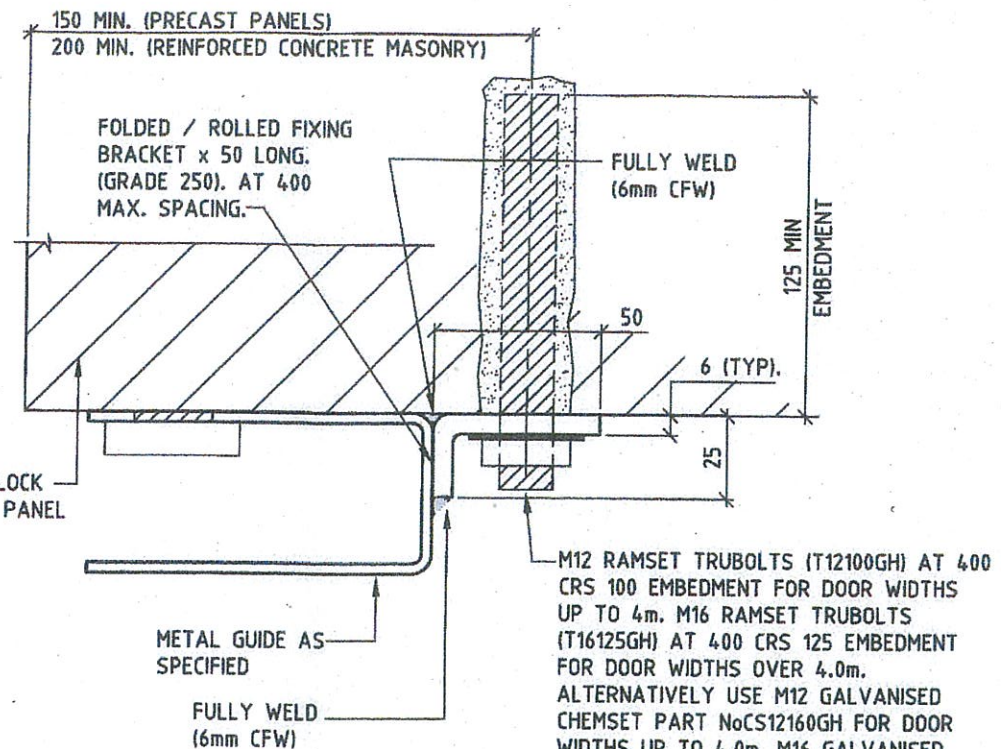

ROLLER DOOR GUIDE TO BUILDING FIXING

NTS - (FIXING TO BLOCKWORK OR CONCRETE)

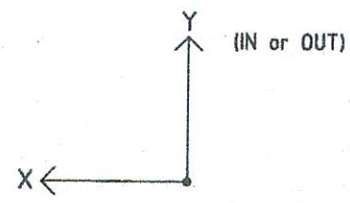

REACTIONS ON DOOR GUIDE

REFER TABLE ON SHEET 1

Product name
ROLLER SHUTTER DOORS 0.8mm BMT WITH WIND LOCKS

Product Description
ROLLER SHUTTER DOORS 0.8mm BMT WITH WIND LOCKS

Manufacturer's Name
ARCO (QLD) PTY LTD
PH (07) 38078041

- Design Criteria**
1. ULTIMATE DOOR DESIGN RESISTANCE 3.0 kPa.
 2. ROLLER DOOR SUPPORT STRUCTURE TO BE DESIGNED BY MAIN BUILDING DESIGN ENGINEER FOR LOADING INDICATED. SEPARATE SECTION 40 CERTIFICATE IS REQUIRED FOR MAIN BUILDING DESIGN.
 3. SUITABILITY OF DOOR FOR ACTUAL SITE CONDITIONS TO BE MADE BY MAIN BUILDING DESIGN ENGINEER. (LIMITED TO 3.0kPa ULTIMATE DESIGN PRESSURE).
 4. THE INSTALLED ROLLER DOOR IMPOSES SIGNIFICANT FORCES ON THE MAIN BUILDING STRUCTURE. THE IMMEDIATE SUPPORTING STRUCTURE MUST BE DESIGNED TO RESIST THE LOADINGS APPLIED AT EACH END OF THE DOOR AS INDICATED IN THE TABLE. A SEPARATE SECTION 40 CERTIFICATE SHALL BE OBTAINED COVERING THE IMMEDIATE SUPPORTING STRUCTURE.
 5. THE RATED DESIGN WIND LOAD RESISTANCE FOR EACH DOOR WIDTH IS AS INDICATED IN THE TABLE. THE STRUCTURAL ENGINEER INVOLVED WITH THE MAIN BUILDING DESIGN SHALL VERIFY THAT THE STATED DESIGN RESISTANCE EXCEEDS THE SITE SPECIFIC DESIGN WIND LOADING.
 6. THE DOORS HAVE NOT BEEN TESTED FOR DEBRIS IMPACT AS INDICATED IN AS1170.2. THE BUILDING SHALL BE DESIGNED ON THE BASIS THAT THE DOOR CAN BECOME A DOMINATE OPENING. INTERNAL PRESSURES FOR THE MAIN BUILDING DESIGN SHALL BE SELECTED FROM TABLE 5.1(B) OF AS1170.2.

- Limitations**
1. 6500 MAX DOOR HEIGHT
 2. 8000 MAX DOOR WIDTH
 3. END GAPS MUST BE SET AS INDICATED IN TABLE.
 4. 10,000 MAX BUILDING EAVES HEIGHT
 5. LOCAL PRESSURE EFFECTS ARE DEPENDANT ON THE FINAL BUILDING CONFIGURATION. WHERE DOORS ARE LOCATED WITHIN 6.0m OF AN EXTERNAL CORNER, THE DOOR SHALL BE ASSESSED FOR LOCAL PRESSURE EFFECTS IN LINE WITH ITEM 1 OF THE DESIGN CRITERIA STATED ABOVE, AND THE DESIGN REAPPRAISED AS REQUIRED. THE ASSUMED MAXIMUM PLAN DIMENSION (B or D) FOR THE CALCULATION OF LOCAL PRESSURE DIMENSION 'a' SPECIFIED IN CLAUSE 5.4.4 OF AS1170.2 IS 36.0m.
 6. IT IS CRITICAL THAT THE ROLLER DOOR WIND LOCKS BE SET WITH THE END GAP INDICATED IN THE TABLE. THE SLAT & WINDLOCK SHALL BE ACCURATELY INSTALLED SO THAT THE SPECIFIED END GAP IS ACHIEVED.
 7. ALL WELDED CONNECTIONS SHALL BE COLD GALVANISED.
 8. THE ROLLER DOOR INSTALLATION SHALL BE TREATED AS REQUIRED IN ORDER TO COMPLY WITH THE DURABILITY REQUIREMENTS OF THE BCA FOR THE ACTUAL SITE EXPOSURE CONDITIONS.
 9. PERSONNEL DOORS ARE NOT PERMITTED WITHIN THE ROLLER SHUTTER.

Accepted for Inclusion

DTCM ref: M/176/011 SHEET 2 OF 2

Chairman's Signature:

Chairman's Name: STEVEN J EHRLICH

Date of Approval: 29/11/2012
Expiry Date: 29/11/2015

Notes covering basis of DTC (Relevant test report etc)
REFER TO NJA CONSULTING REPORT - REFERENCE No. 11106-028-02
THE MAXIMUM DOOR DESIGN RESISTANCE & APPLIED GUIDE FORCES HAVE BEEN CALCULATED USING TEST DATA & THEORETICAL ANALYSIS CARRIED OUT BY NJA CONSULTING:- AS REPORTED IN SUMMARY REPORT REF:- 09208-001-01.

****Certifying Engineer's Certification**
Name: RONALD A. BELL
Registration Number: 60596 ES
Date: OCTOBER 2011
Signature:

***Design Engineer's Certification**
Name: DARREN McDONALD
Registration Number: 24619 ES RPEQ 5453
Date: OCTOBER 2011
Signature:

**registered as a structural engineer in Northern Territory

*registered as a structural engineer in Australia